

VARiO-DRiVE

**Instruction Manual
English (EN)**

Electric drive unit



Table of contents

1	Safety Regulations	2
2	Copyright ©.....	3
3	Non-liability	4
4	Warranty	4
5	Declaration of conformity	5
6	Machine parts	6
7	Connections and type plate	7
7.1	Control box with type plate	7
7.2	Vario Drive assembly with hand grip	8
8	Controls Vario Drive	9
9	Installation and startup	10
9.1	Mounting on the HM-2000 EVO	10
9.1.1	Earthing.....	10
9.1.2	Installation of the control box.....	10
9.2	Mounting to wall (AV-Mobile)	11
9.3	Connecting the control box.....	12
9.4	Connecting to the power network.....	13
9.4.1	220-240VAC / 50-60Hz	13
9.4.2	100-125VAC / 50-60Hz	13
10	Handling and operation	14
10.1	Troubleshooting	14
11	Spare parts	15
12	Schematic diagramm	16
12.1	Control box	16
12.2	Electric motor + frequency transformer.....	17
12.3	Hand grip with switch key button.....	18
13	Maintenance	19
13.1	Fuse for control box	20
14	Technical data	21

1 Safety Regulations



We would like to draw your attention to some dangers which may occur. You should therefore read the following instructions carefully and proceed accordingly.

- ⚡ It is prohibited to run the machine in moist, dusty or explosive environment! There is a danger of a short circuit!
- ⚡ The isolation of the flexible drive shaft as well as all visible cables have to be checked frequently!
- ⚡ The Vario Drive must be used only as a mechanical rotary drive for the VGX-21 or any further MIRA valve seat refacing unit. It is not intended to use the machine in a non- designated application and therefore will not be accepted by MIRA liability- and warranty declarations.
- ⚡ Powering any other tools and devices with the Vario Drive is NOT suitable and will cause an unnecessary risk of injury!
- ⚡ Overpasting or bridging of the handle switch is dangerous!
- ⚡ Safety Goggles have to be worn while using the unit!
With long hair, either a head covering must be worn or the hair must be bound up!
- ⚡ The rotating spindle of the Vario Drive causes a risk of injury!
- ⚡ Power must be disconnected prior to any electrical work or repair operations!
- ⚡ Repair operations may only be performed by the manufacturer (Minelli Corporation) or by the local Mira representative!
- ⚡ Use only genuine MIRA spare parts that are listed in the respective instruction manuals!
- ⚡ Avoid contact with the electrical circuits of the machine! => Risk of electrocution!
- ⚡ Modifications of the electronic components may have serious consequences!

Earthing of the workstation

To minimize shock hazard, the Vario Drive system must be connected to an electrical ground. Earthing equipment must be connected to the protective earthing conductor of the power supply!

Do not use in explosive environment!

Operation of this machine in the presence of inflammable gases, fumes or dust may cause an ignition of this environment and has to be prevented.

CAUTION!

1. It is not permitted to operate the machine in dusty surroundings as there is a risk of fire resulting from the overheating of small particles.
2. To avoid shock hazards, do not expose this machine to moisture, rain or dew as this may cause an electrical short between mains and controls.
3. Installation, adjustment and service of this device must be made by qualified personal only. Works or repairs on electrical parts of the machine is very dangerous because of the high voltages the circuit is working with. These high voltages are capable of causing death and are present even after disconnecting mains. Before starting servicing and repairs, it is essential to disconnect any mains.
4. It is not permitted to work on the outputs if the power supply is switched on, even if the connected motor is not activated or the drive is interlocked.
5. Operation of this machine without a mechanical ON/OFF switch and a fuse in the supplying wiring is not permitted.
6. Do not attempt internal service or adjustment unless another person, capable of disconnecting mains and rendering first aid, is present.
7. This machine should never be used as a safety device or for realizing an emergency function. A malfunction of the connected motor even with switched on mains cannot be prevented.
8. Do not touch the electrical parts of the devices. During operation the electrical parts are carrying dangerous voltages and might lead to death. In addition, the machine can be damaged if the electrical circuit is touched, as a result of static discharge effects.
9. To prevent additional hazards, do not make modifications or installation of substitute parts. Before any modification, installation of substitute parts or additions are made, ask for the authorisation of the manufacturer (Minelli Corporation).
10. During installation and operation of the machine, pay attention to any further safety regulations and advices specified in the respective chapters in this instruction manual.

2 Copyright ©

The exclusive copyright of this instruction manual remains in the hands of the MINELLI Corporation (MIRA).

This instruction manual is appointed to the operator and the corresponding employees.

**Minelli Corporation
MIRA Division
Mattenstrasse 3
8330 Pfäffikon ZH
Switzerland**

For the provided technical documentation see the authorised person in chapter „Declaration of conformity“ on page 5.

3 Non-liability

The Vario Drive may only be operated according to the instruction manual. The manufacturer refuses to accept any liability for accidents and damages caused by incorrect operation and non-designated use. He also refuses any liability for alienated use of the machine.

4 Warranty

In case of manufacturing or material defects Minelli Corporation will replace the defective part or parts at no charge within 12 months after the date of final purchase. No further claims can be covered under the warranty. Defective parts must be returned along with proof of purchase. Warranty does not cover any subsequent damage caused by these defective parts. Warranty does not cover non-designated handling, the use of incorrect electronic parts or deliberate damage, nor does it cover shipping and packing costs.

5 Declaration of conformity

MINELLI[®]

Minelli AG
 Mattenstrasse 3
 8330 Pfäffikon ZH
 Schweiz/ Switzerland
 www.minelli.ch
 sales@minelli.ch

Konformitätserklärung
Déclaration de conformité
Declaration of conformity
Dichiarazione di Conformità

Wir/Nous /We/Noi,

Minelli AG
Mattenstrasse 3
CH-8330 Pfäffikon ZH

erklären in alleiniger Verantwortung, dass das Produkt
déclarons de notre seule responsabilité que le produit
 bearing sole responsibility, hereby declare that the product
 dichiariamo sotto la nostra sola e completa responsabilità che il prodotto

Beschreibung des Produkts
 Vario Drive
Description du produit
 Vario Drive
Description of product
 Vario Drive
Descrizione del Prodotto
 Vario Drive
Typenreihe/ Série type / Type Series/ Serie Tipo
 0318

auf das sich diese Erklärung bezieht, mit der/den folgenden Norm(en) oder normativen Dokumenten übereinstimmt:

auquel se rapporte la présente déclaration est conforme aux normes ou aux documents normatifs suivants:
 referred to by this declaration is in conformity with the following standards or normative documents:
 riferente a questa dichiarazione è conforme alle seguenti regole e normative:

Bestimmungen der Richtlinie <i>Désignation de la directive</i> Provisions of the directive Denominazione della Direttiva	Titel und/oder Nummer sowie Ausgabedatum der Norm(en) <i>Titre et/ou numéro ainsi que date d'émission de la/des norme(s)</i> Title and/or number and date of issue of the standard(s) Titolo e/o numero e data di promulgazione della norma
2006/42/EG: Maschinenrichtlinie <i>2006/42/CE: Directive sur les machines</i> 2006/42/EC: Machinery directive 2006/42/CE: Direttiva Macchine	SN EN 1037+A1: 2008-07 DIN EN ISO 12100: 2011-03
2014/30/EU: EG-EMV Richtlinie <i>2014/30/UE: Directive CEM</i> 2014/30/EU: EMC directive 2014/30/UE: Direttiva CEM	SN EN 60204-1: 2006-06 SN EN 60269-1+A1+A2: 2015-05 DIN EN 61800-3: 2012-09 DIN EN 55011: 2018-05
2014/35/EU: Niederspannungsrichtlinie <i>2014/35/UE: Directive basse tension</i> 2014/35/EU: Low voltage directive 2014/35/UE: Direttiva bassa tensione	

Ort und Datum
Lieu et date
Place and date
Luogo e Data
 Pfäffikon ZH, 20.07.2023

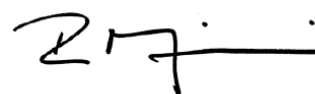

Reto Minelli (CEO/Geschäftsführer)
L'administrateur délégué
 General Manager
 Amministratore delegato

VARIO DRIVE (Series 0318)

The Vario Drive system allows an efficient and fatigue-proof refacing of valve seats via the manually operated MIRA valve seat refacing units (VGX-21, VG-91 etc.). Through the steady rotation of the electric drive unit, it is possible to accomplish a constant high-quality surface. The provided control box enables a stepless speed control between 0 to 200rpm and can be positioned individually with a magnetic clamp. The driving pin of the Vario Drive hand grip is compatible with any MIRA valve seat refacing unit. The Vario Drive can be mounted on to the HM-2000 EVO workstation with the respective fastening material (accessories). Otherwise, the Vario Drive can be wall-mounted beside the AV-Mobile workstation. See also chapter 9.2 on page 11.

6 Machine parts

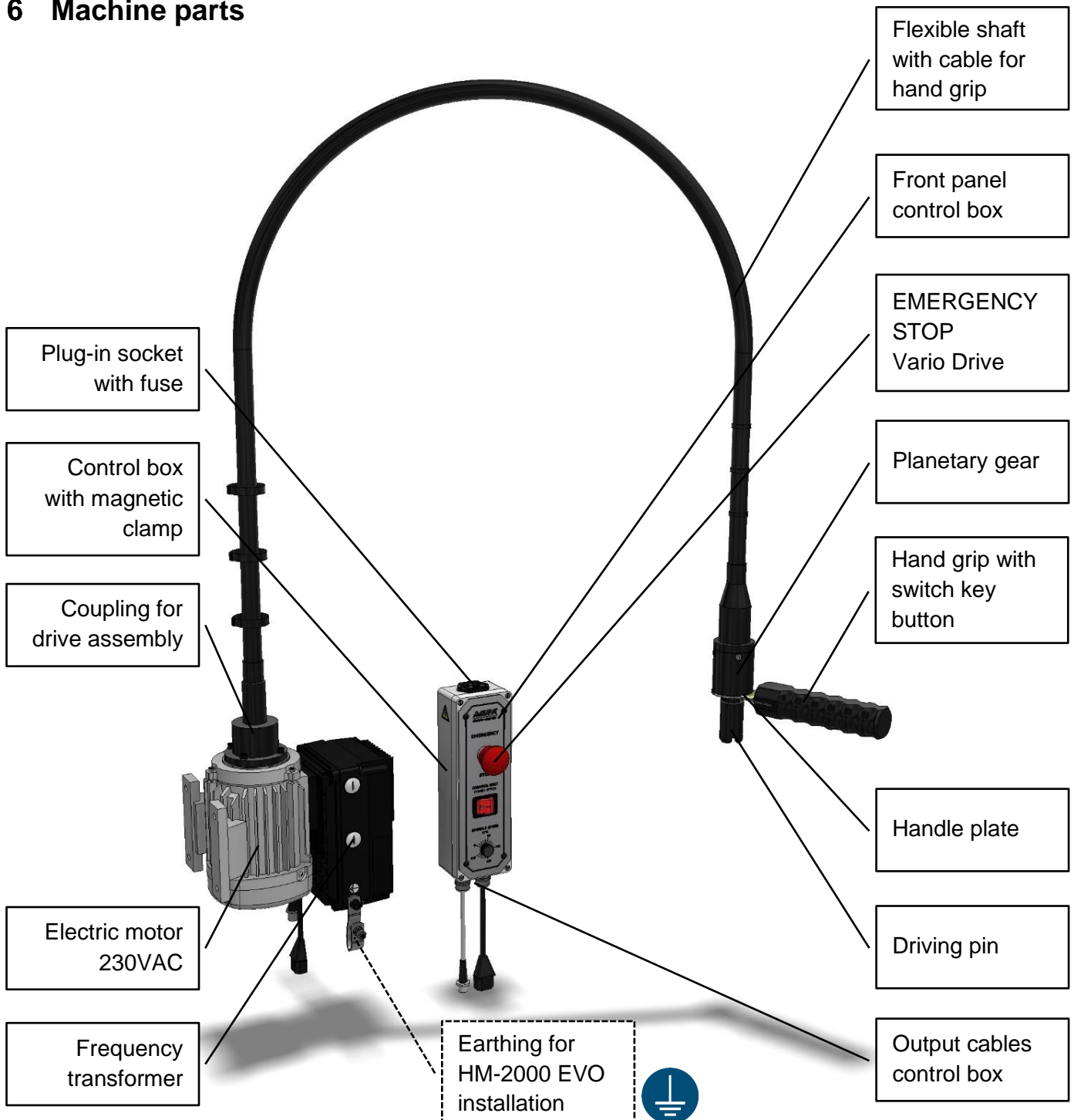

7 Connections and type plate

The Vario Drive includes the modules **Control box**, **Vario Drive assembly** and **hand grip with switch key button**. The connection of these modules, among each other, is illustrated in chapter 9 on page 10 and schematically on chapter 12 on page 16. The type plate is located on the rear side of the Vario Drive control box. => Manipulation and removing of the type plate are not allowed. The original specifications on the type plate (serial-no., fabrication-no. and technical specifics) must be in readable condition if service repairs and warranty is required.

7.1 Control box with type plate

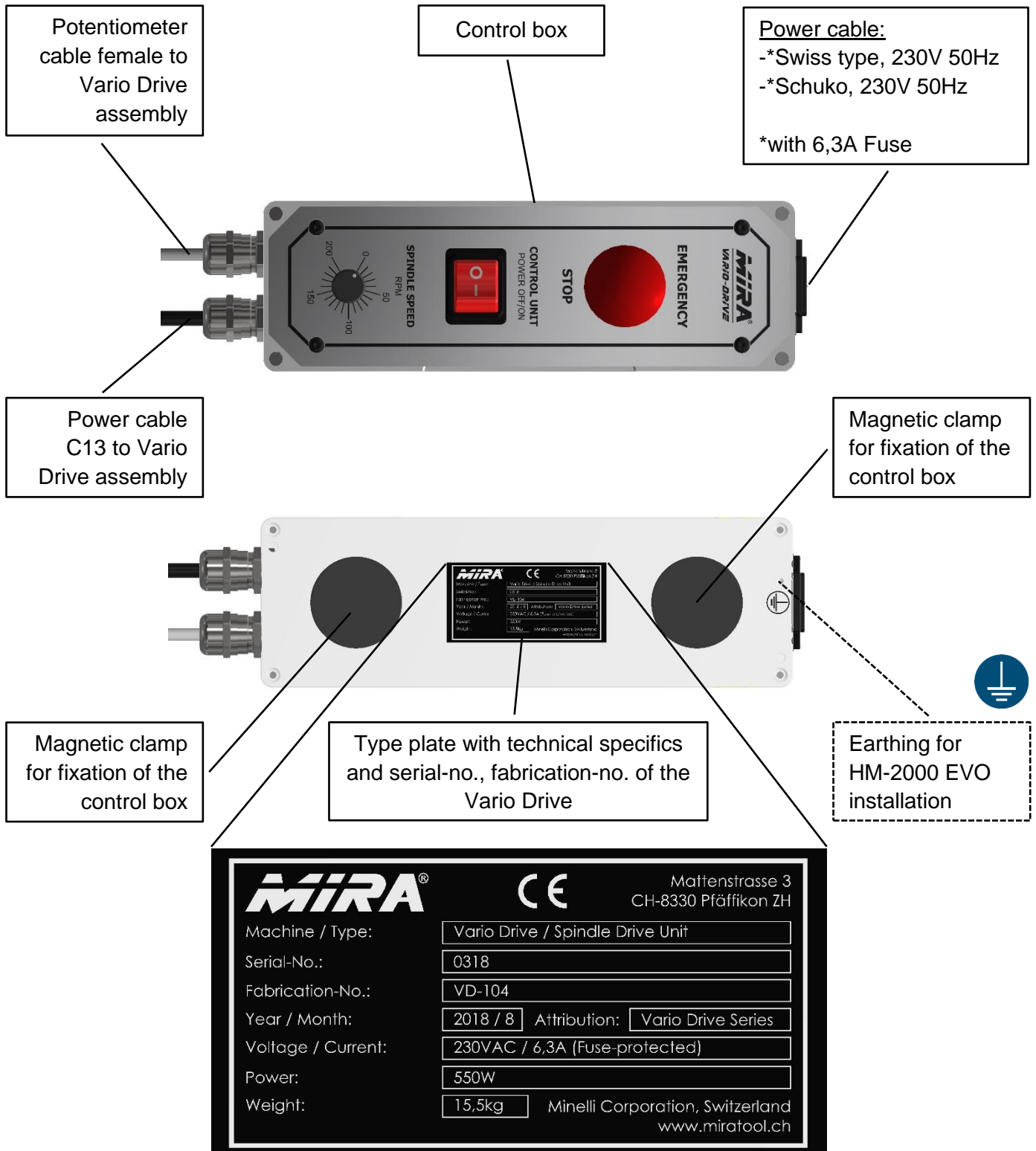
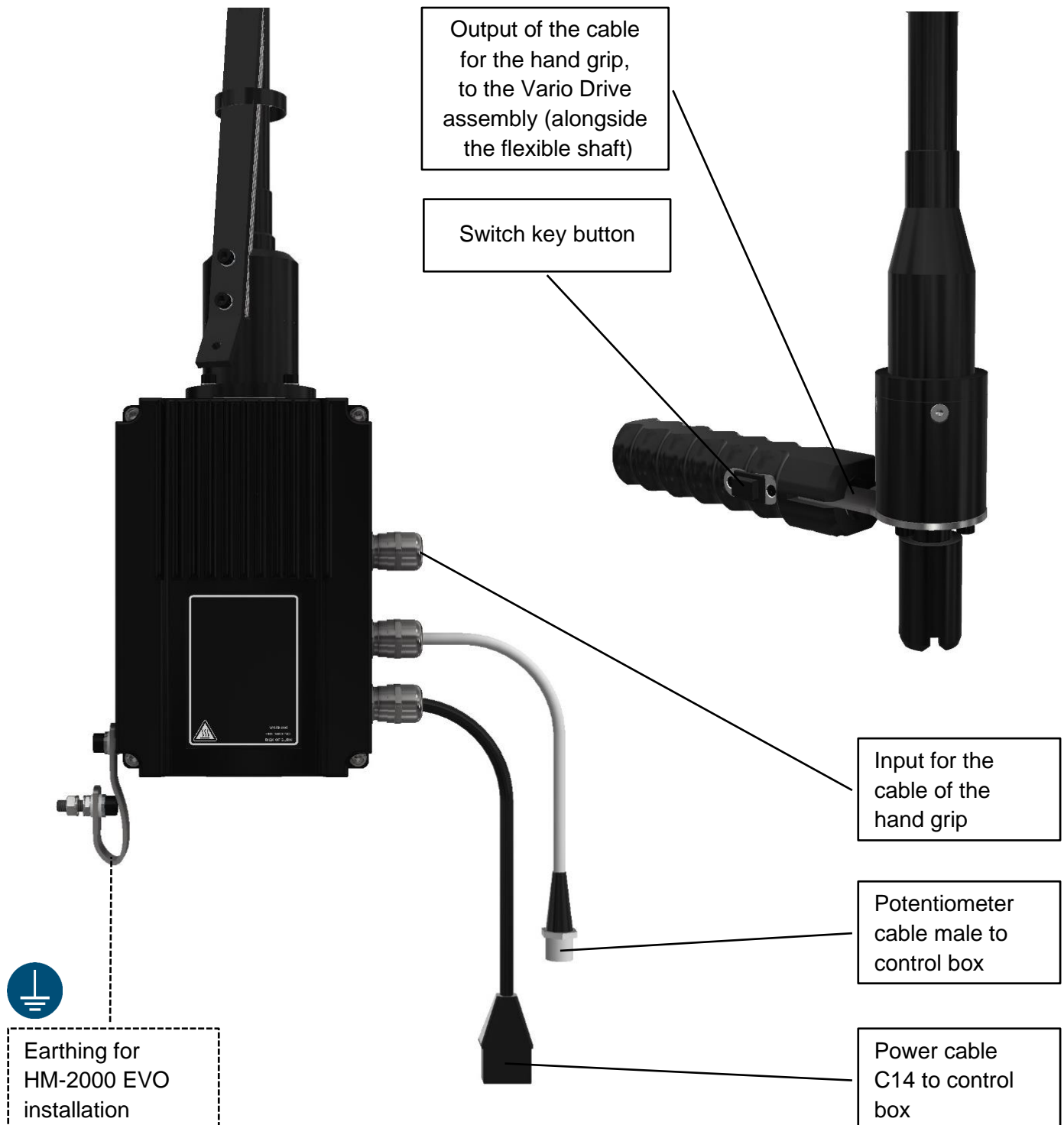

Fig. 1 - Type plate Vario Drive

7.2 Vario Drive assembly with hand grip



8 Controls Vario Drive



9 Installation and startup

The installation of the Vario Drive system can be carried out in two variations: **Mounting on the HM-2000 EVO / Mounting to wall (AV-Mobile)**. The Vario Drive assembly will be installed on the respective workstation firstly, then followed by the fix installation / cable connection of the Vario Drive control box.



Pay attention! The use of an external voltage transformer is required if the installed Vario Drive will be operated in a 110VAC power network!

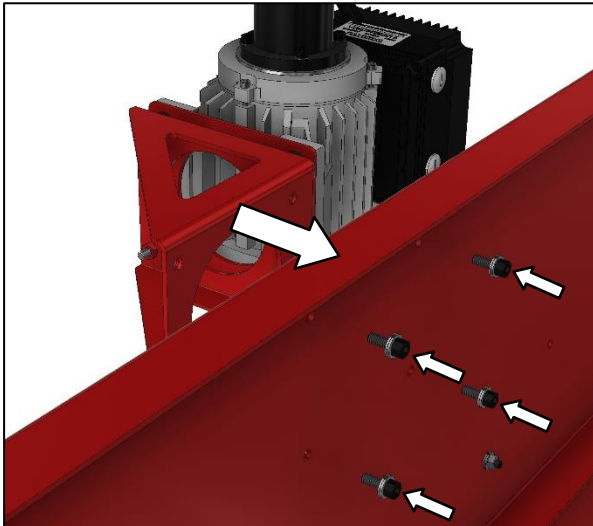

Fig. 2 - Mounting on the HM-2000 EVO

9.1 Mounting on the HM-2000 EVO

The Vario Drive assembly will be mounted on the rear side of the HM-2000 EVO. If the mounting material was not provided with the Vario Drive system, the additional HM-installation can be supported with the following mounting kit:

- 1x Mounting angle with fastening material
- 4x Rubber stops
- 4x Inhex screw
- 4x Nordlock lock washer

Order-No.: 12041.2.6439 Mounting angle Vario Drive

The mounting angle kit will be provided with the required fastening material (pre-installed) and can be mounted on the HM-2000 EVO workstation as illustrated beside.



ATTENTION

- It is necessary to carry out this setup work with 2 persons. Risk of an accident and severe material damage by incorrect handling!
- The Vario Drive assembly must be connected in a de-energised mode! Isolate the Vario Drive from the power network and secure it against unintended re-powering.

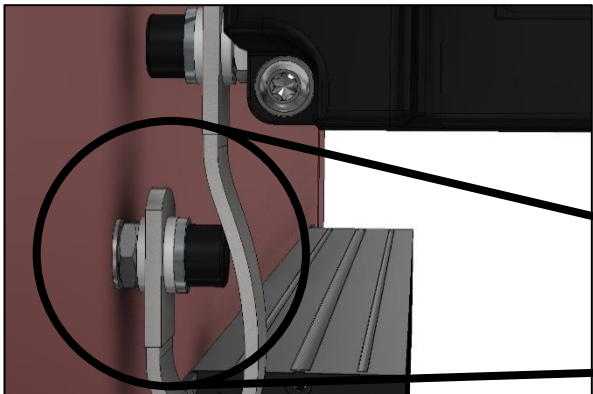

Fig. 3 - Earthing of the Vario Drive assembly

9.1.1 Earthing

The earthing assembly is pre-installed on the frequency transformer of the Vario Drive assembly. After mounting the Vario Drive assembly, the earthing must be secured against the rear sheet panel of the HM-2000 EVO. => **Installation by the customer.**



The earthing can be mounted corresponding to the figure beside. It can be attached on the rear sheet panel with the provided mounting material. Secure the earthing from the inside of the rear sheet panel with a hex nut and a lock washer.

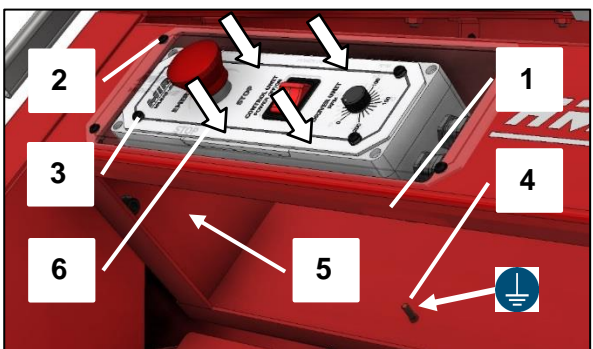

Fig. 4 -Vario Drive control box

9.1.2 Installation of the control box

1. Unscrew the 6 pan head screws and remove the HM-service sheet (HM-front panel).
2. Remove the left HM-front cover.
3. Remove the 4 pan head screws on the control box front plate and mount the HM-front cover onto the control box.
4. Connect earthing lead to the rear side of the control box as well as the power cable to the left side (plug-in socket).
5. Lead the power- and connecting cables through the left cable bushing to the rear side of the HM-2000 EVO and connect them according to page 12.
6. Insert and mount the control box with the HM-front cover into the HM-front panel. => Close the HM-service sheet.

9.2 Mounting to wall (AV-Mobile)

It is recommended to wall-mount the Vario Drive system if combining it with an AV-Mobile workstation. To use the entire working area of the Vario Drive and reach the controls in a comfortable manner, make sure the assembly will be installed approximate to the AV-Mobile workstation.



For wall-mounting the Vario Drive, there has to be ensured that the mounting will suffice under the expected loads (weight of Vario Drive as well as operational stress).

=> Weight of the Vario Drive system: 15kg

An even, smooth and flawless base support (wall) is required to ensure a firm, precise mounting for the system. Furthermore, only choose wall structures that are to be expected to last against the expected loads. Pure gypsum- and wooden boards are not suitable for load-bearing walls!



ATTENTION!

It is necessary to carry out this setup work with 2 persons. Risk of an accident and severe material damage by incorrect handling!

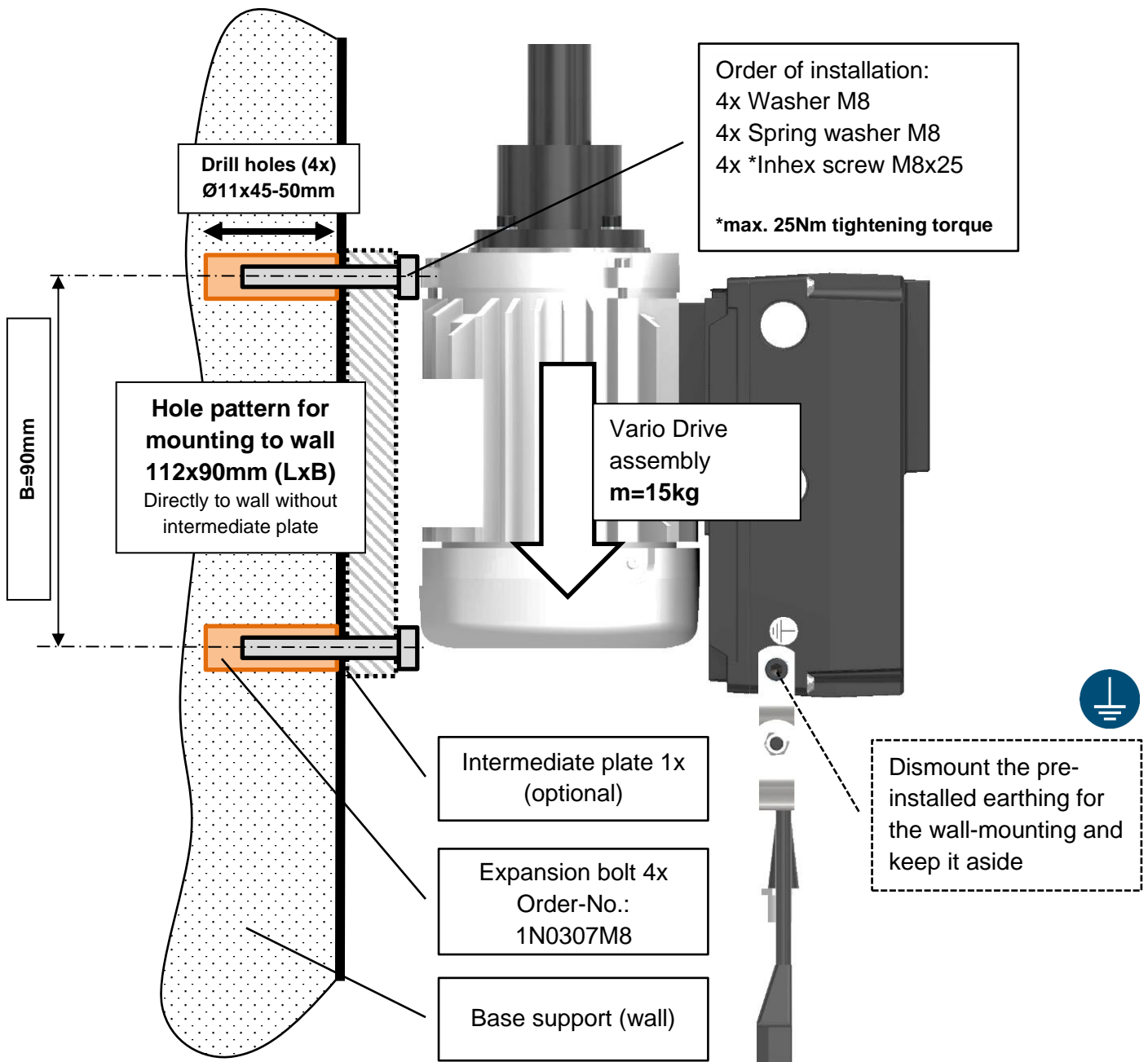

9.3 Connecting the control box

On the rear side, the control box is equipped with two magnetic clamps and can therefore be positioned flexibly on a magnetic surface (metallic sheet, square tube etc.).



ATTENTION!

Pay attention that the control box must be positioned near the workstation, if an emergency occurs and the emergency stop has to be pushed down immediately!



The control box must be connected in a de-energised mode to the Vario Drive assembly! Isolate the Vario Drive from the power network and secure it against unintended re-powering.

Connect the control box to the connection cables of the Vario Drive assembly according to the illustration below:

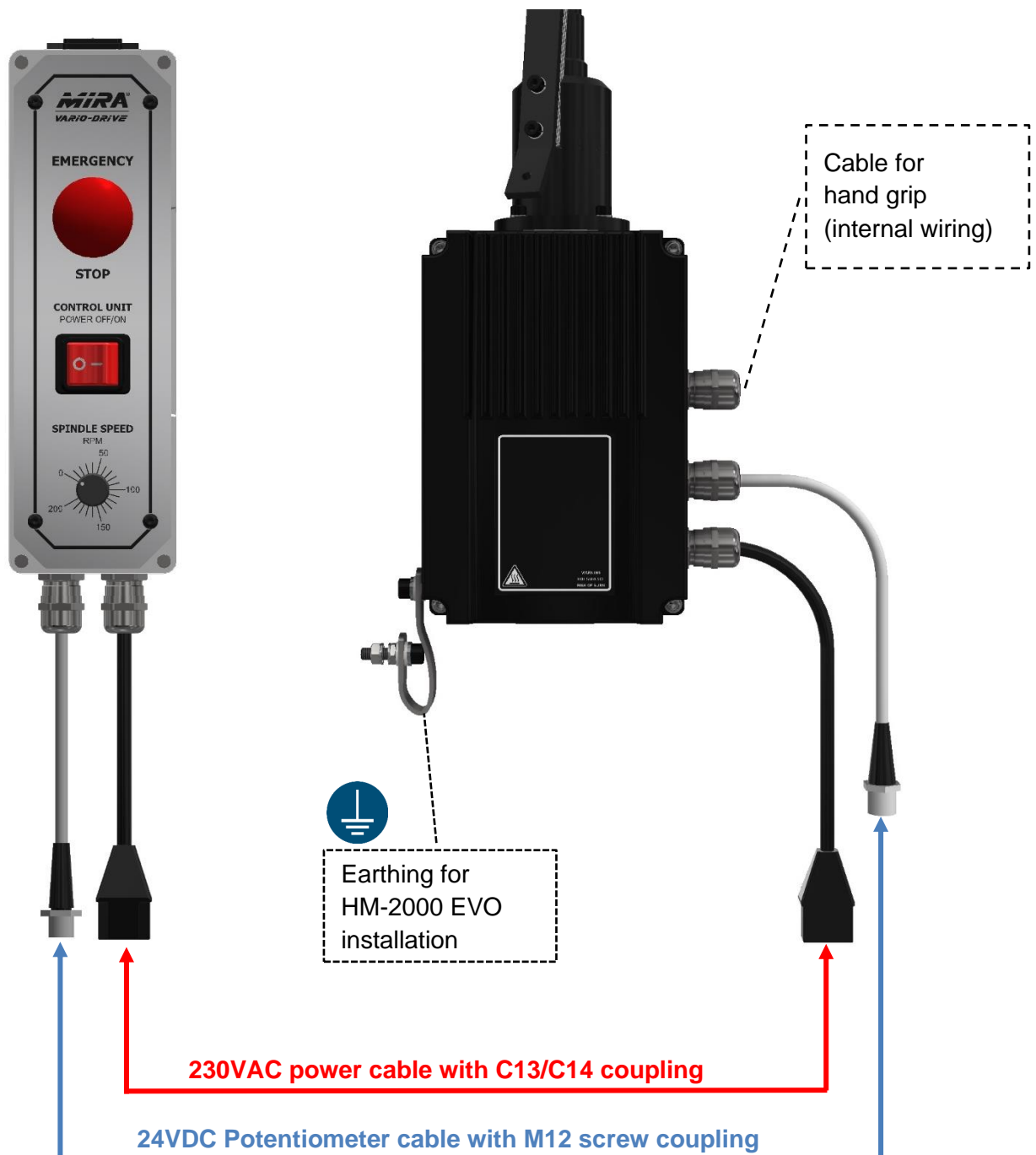

9.4 Connecting to the power network

9.4.1 220-240VAC / 50-60Hz

This is the standardised power network for operation in the following countries: **Switzerland, EU, UK, Africa, Russia, Australia, Asia and parts of Latin America.**

=> The Vario Drive control box can be connected, with the provided Schuko / Swiss type power cable, directly to the local 230VAC power network or to the multiple socket of the HM-2000 EVO workstation.

9.4.2 100-125VAC / 50-60Hz

Only for contries with 100-125VAC power network!

For operation in the following countries: **USA, Japan, Central America und parts of Latin America**, the use of an external voltage transformer is required. The voltage transformer **provides** the required **220-240VAC / 50-60Hz** electricity from the local 100-125VAC power network.

The provided power cable of the Vario Drive control box will be connected to the output (Schuko) of the voltage transformer. The voltage transformer will then be connected to the local power network (Nema 5-15).

The voltage transformer unit must be positioned in a **dry environment** and must not be exposed to mechanical vibrations. It is recommended to position the voltage transformer on the ground, near the workstation. The connection distance **should not extent 1,5-2,0m**.

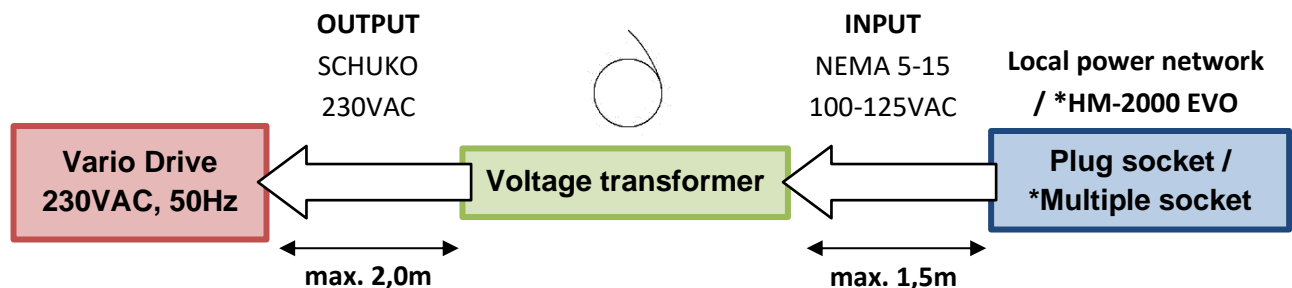

- Operating the Vario Drive without voltage transformer is allowed **ONLY** in a 230VAC, 50-60Hz power network!
- The voltage transformer has to be connected in a de-energised mode!
- **Do not** connect any 110VAC devices directly to the external voltage transformer! These electrical devices (working lamps, measuring devices etc.) will be destroyed by applying higher voltages (<230VAC). Imminent fire hazard through electrical overload.
- The voltage transformer must not be opened in any case. Imminent danger of electrocution and short-circuit fault!
- To lead away the emerging heat energy from the voltage transformer and preventing heat accumulation, the provided working base should be selected sufficient enough.
- Non-observance of these regulations can lead to hazardous electrical shocks, electrocution and material damage as well!

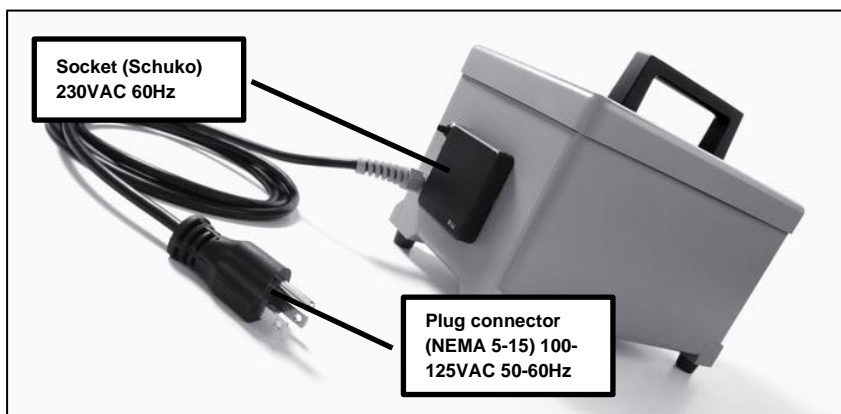

Order-No.:
1KTR00425

Fig. 5 - External voltage transformer

10 Handling and operation

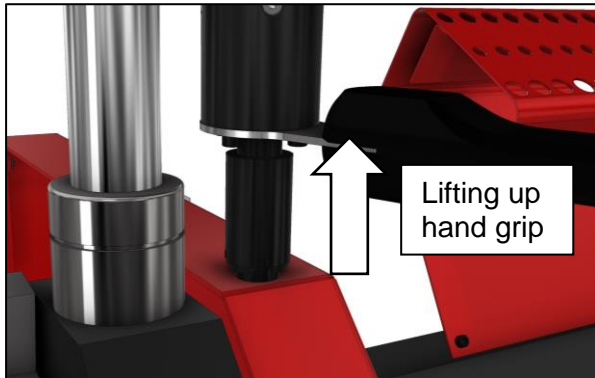

Fig. 6 - Tooling plug for Vario Drive hand grip

The Vario Drive will be activated through switching the main switch on the control box to position 1 (active mode is indicated with red illumination). The Vario Drive hand grip is, for example on a HM-2000 EVO workstation, by default inserted on the tooling plug of the right side wall of the HM-2000 EVO workstation. The hand grip can be lifted up from the tooling plug and, for operation, inserted on the adaptor of the VGX-21.

Important: The EMERGENCY STOP interrupts all electric circuits of the Vario Drive and stops the driving pin from any further rotating. Turn the push button clockwise to release and reset the EMERGENCY STOP.

=> The switch key button must not be pressed down unless the emergency stop is released completely!

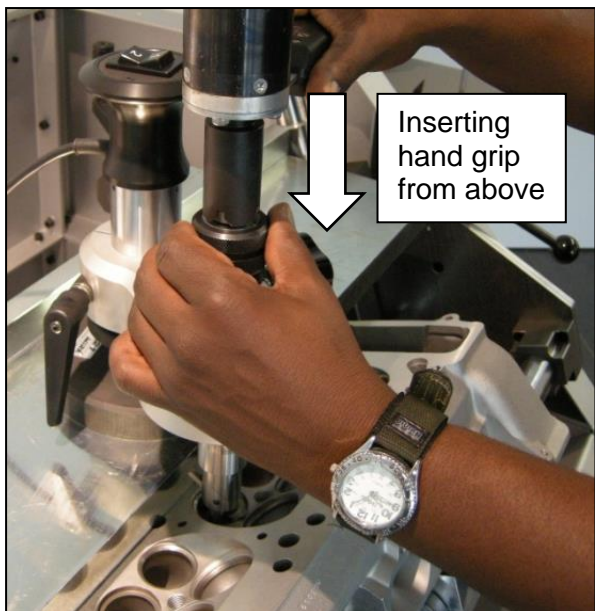

Fig. 7 - Inserting on VGX-21

The required spindle speed can be set on the potentiometer in a range between 0-200min⁻¹. Rule of thumb: high speed for small diameters and low speed for large diameters.



ATTENTION!

Do not use the Vario Drive for driving other devices and tools at all! Risk of injury through rotative tools! Beware of the rotating driving pin of the Vario Drive hand grip!

Attention: The rotation of the driving pin begins / stops with a short delay after pressing down / releasing the switch key button on the Vario Drive hand grip!



Handling and valve seat processing with the VGX-21 as well as tool settings can be reviewed in the respective instruction manual.

Set the spindle speed and then the main switch to position 0 after finishing operations (=>Vario Drive power-off)

10.1 Troubleshooting

The following check questions are designed to help you eliminating possible sources of faults:

1. Is the power supply connected properly? (Local power network => VD control box => VD assembly)
2. Are all plugs connected correctly?
3. Are there any loose contacts?
4. Is the Vario Drive connected to a 230VAC, 50Hz power supply?
5. Is the plug socket or the multiple socket functioning properly?
6. Are both 6,3A fuses from the control box in a proper condition?
7. Is the emergency stop of the VD control box activated? If yes, restore it.
8. Is the ON-OFF switch of the VD control box in position 1? Is it illuminated?
9. Is the switch key button on the hand grip functioning? Push the button => spindle on?
10. Control the position of the potentiometer: => untwist and push switch key button => spindle on?
11. If using a voltage transformer: Is it connected correctly to the power network and functioning?

If the **malfunction** still occurs **after the troubleshooting**, please refer to our technical support at MIRATOOL via sales@minelli.ch

11 Spare parts

From Fabrication-No.: VD-102

Serial-No.: 0318

When ordering spare parts, the serial- and fabrication number must always be indicated.

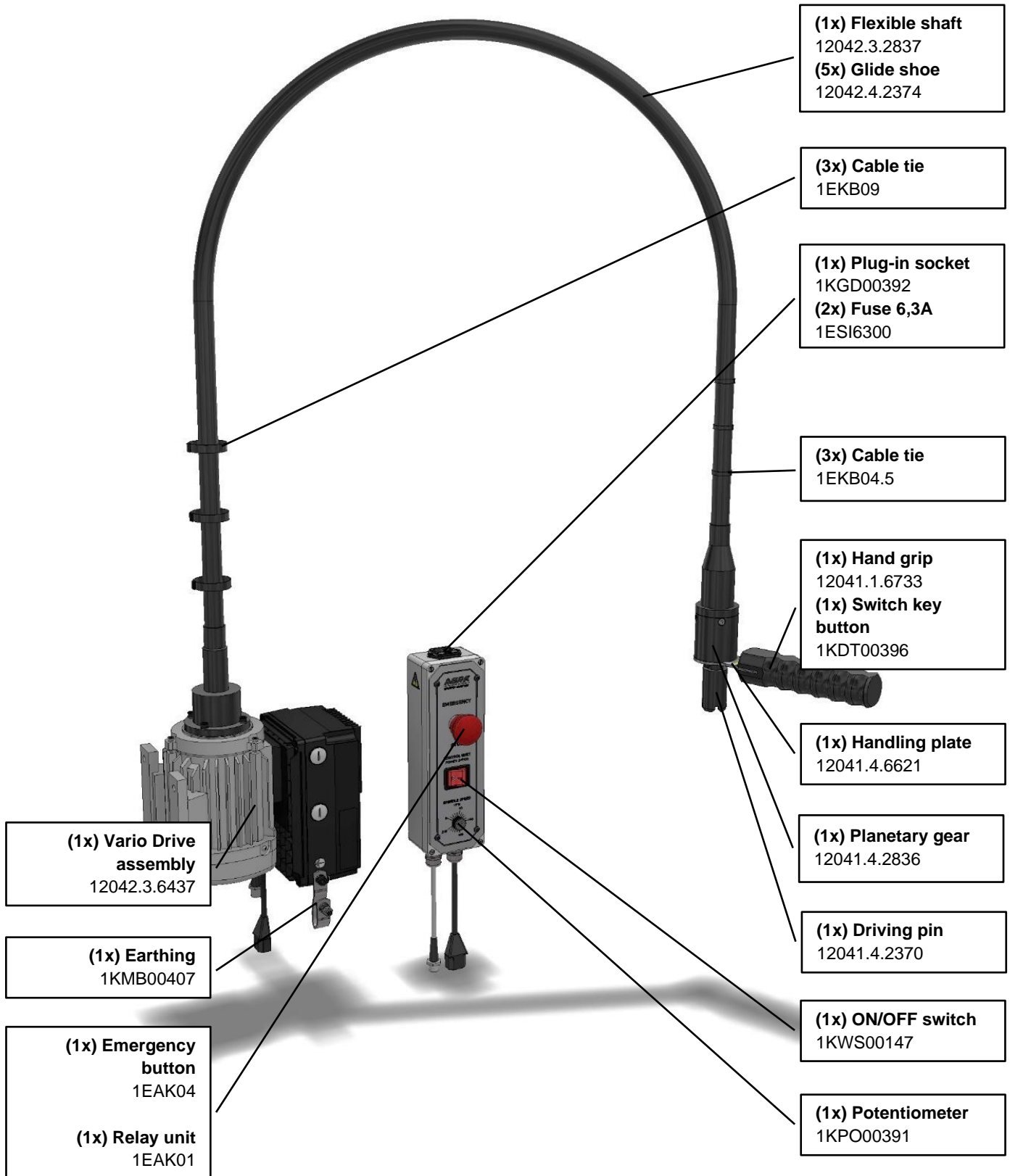

12 Schematic diagram
12.1 Control box

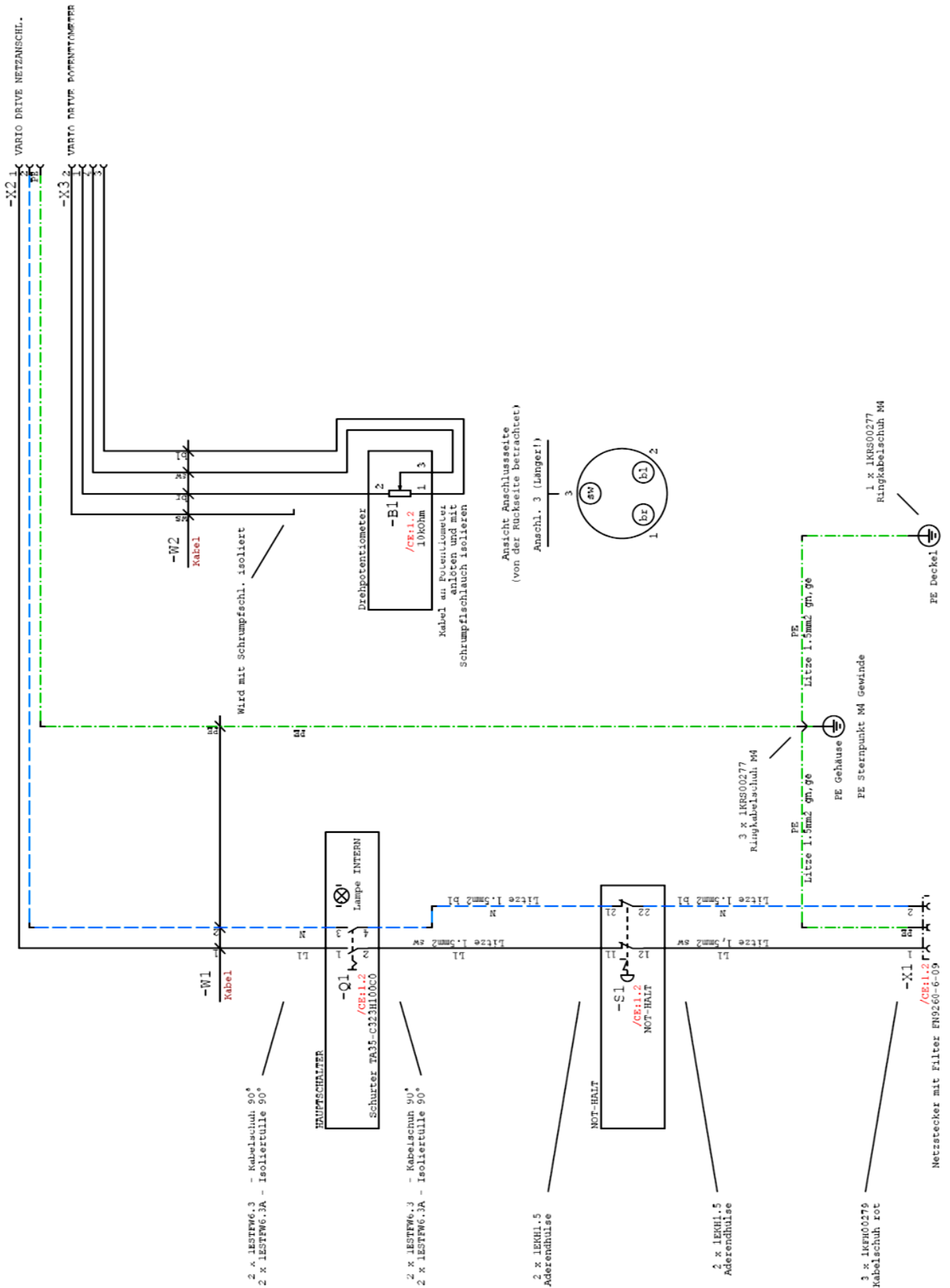

12.2 Electric motor + frequency transformer

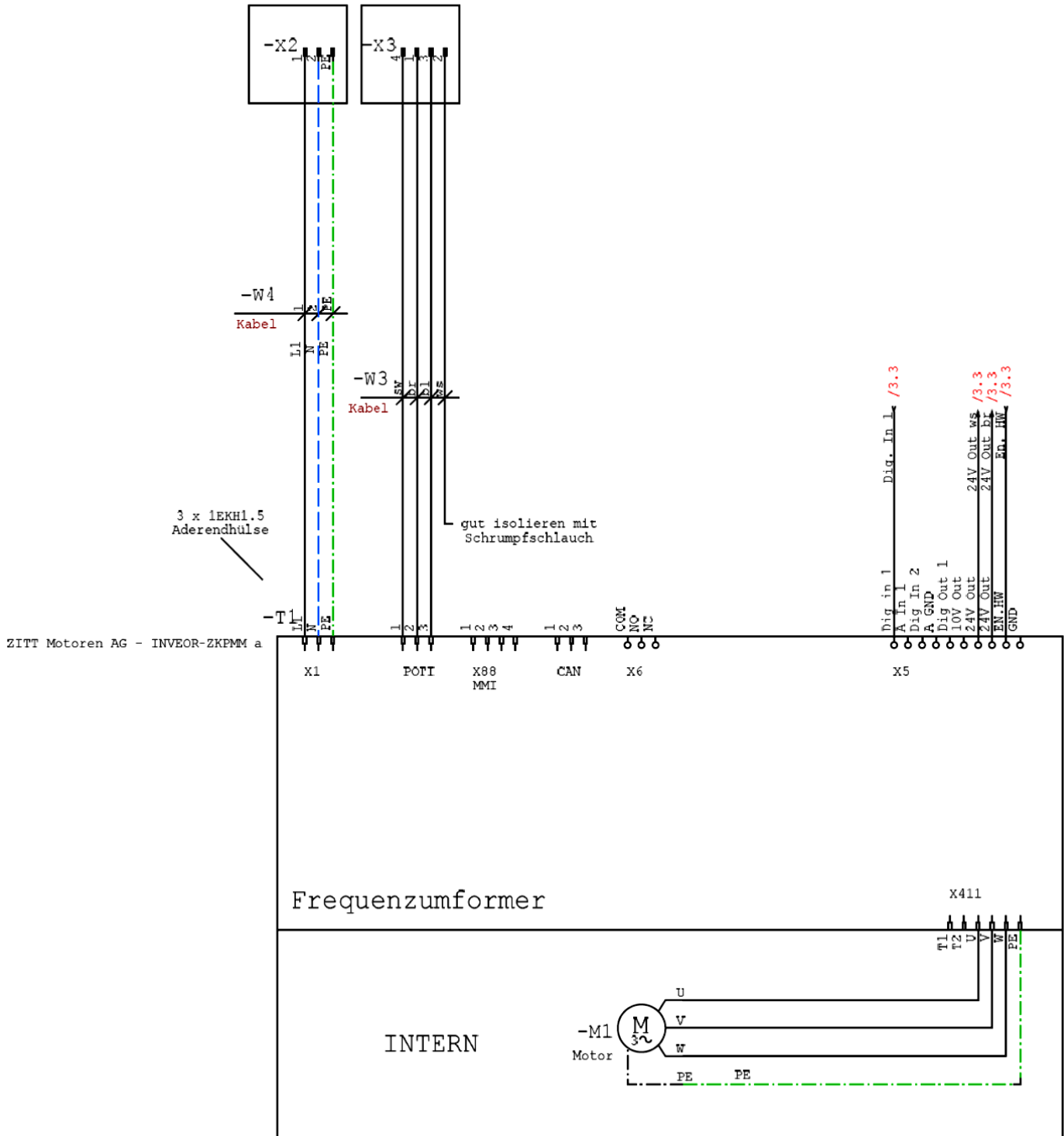

12.3 Hand grip with switch key button

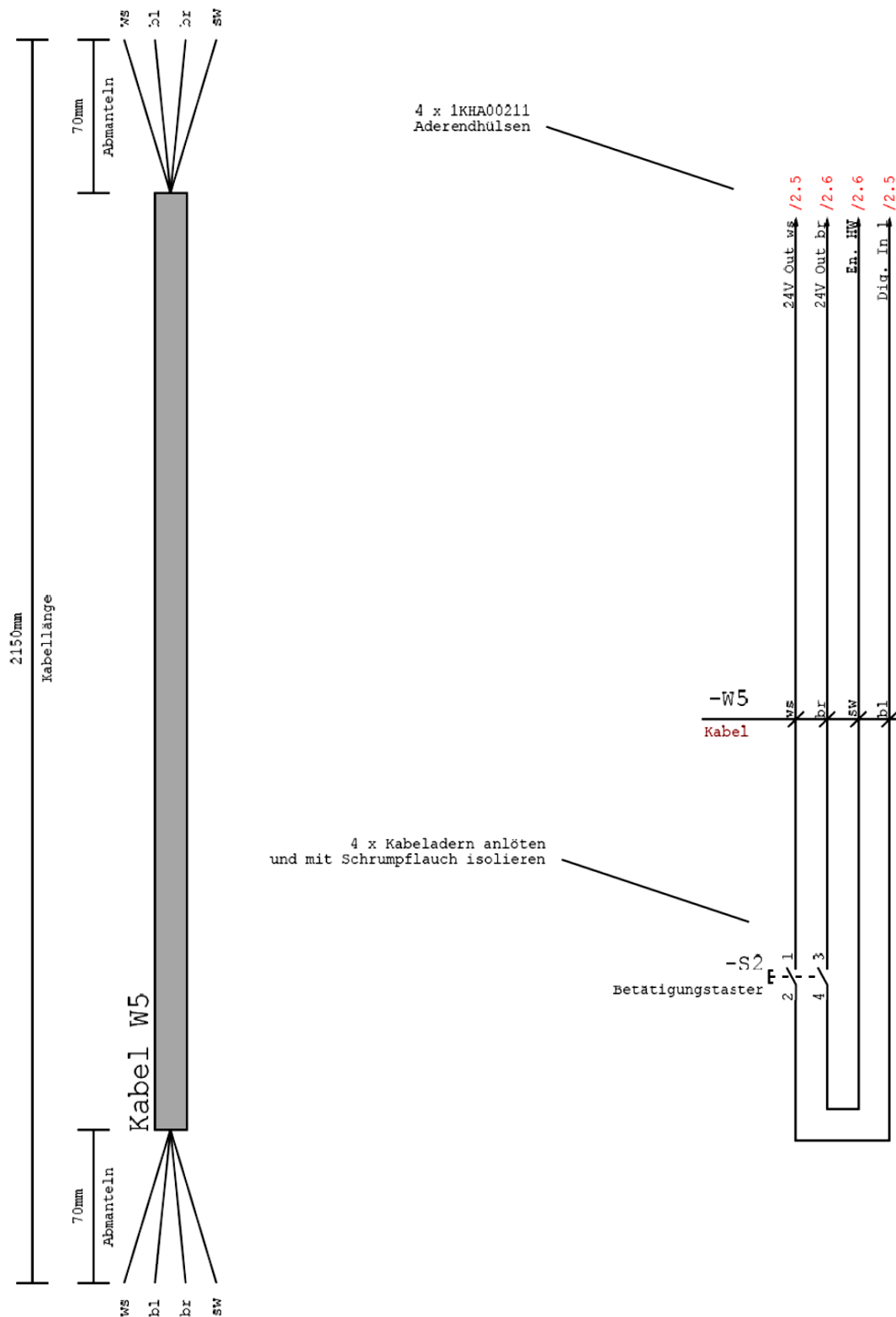

13 Maintenance

Servicing and maintenance can be held at a minimum if the Vario Drive will be operated properly and without any modifications. The use of warm water and a cleaning cloth are recommended for cleaning the anodised and powder-coated surfaces. Do not use any abrasive cleanser (acid, base, wire wool etc.) for surface cleaning.

The following parts and assembly groups should be considered especially for the maintenance:

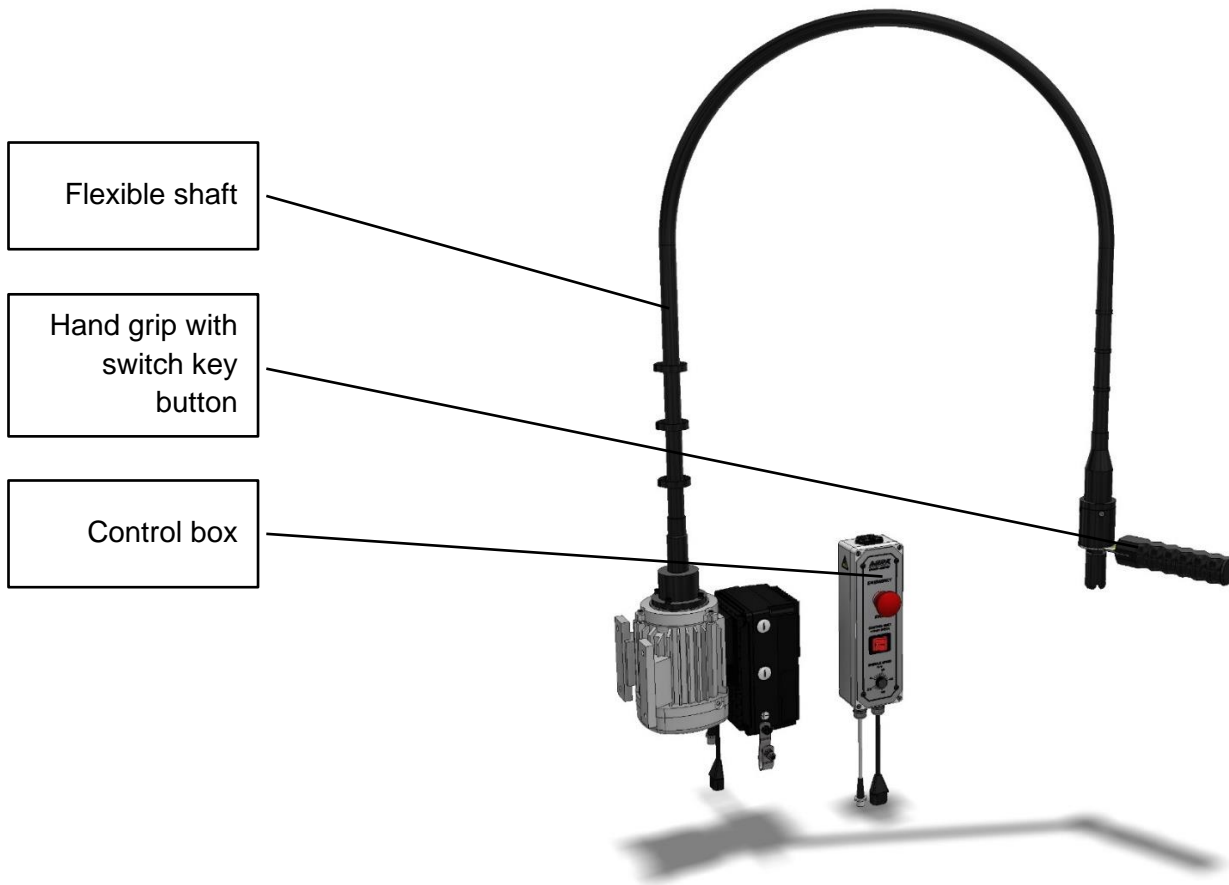



MAINTENANCE RATE

(Increase, if pollution is higher than anticipated)

Weekly

Monthly

Annually

	Weekly	Monthly	Annually
Flexible shaft 	/	Checking the flexible shaft and connection leads for external damages.	Replacing defective and damaged cable ties as needed.
Handgrip with switch key 	In case of pollution: cleaning of the hand grip with a clean brush and a slightly wet cloth	Checking the driving pin for damages. Using rust protection against initial corrosion.	Checking switch key for correct functionality. Contacting manufacturer if switch key is defective
Vario Drive front panel 	In case of pollution: Cleaning of the front panel with a clean soft cloth. Do not use abrasive cleanser!	Checking control elements for correct functioning. Checking the Emergency function in operation and checking of the reset.	Replacing as needed Contacting manufacturer if control elements are defective or damaged

13.1 Fuse for control box

The Vario Drive control box is secured with **two 6,3A fuses** on the power supply side. In case of replacing the fuses, please follow the steps below:



ATTENTION!

The Vario Drive control box must be connected in a de-energised mode! Isolate the control box from the power network and secure it against unintended re-powering!

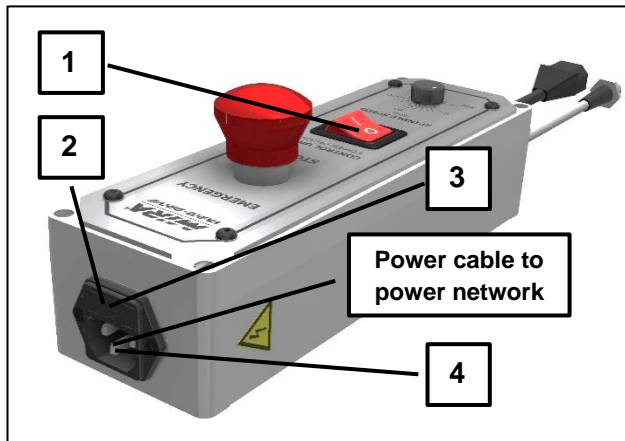

Fig. 8 - Replacing the fuse of the Vario Drive

1. Switch the ON-OFF switch to position OFF and disconnect the power cable from the left side of the control box.
2. Draw out the fuse bin and replace the respective fuses. (max. 2pcs).
3. Insert the fuse bin back inside the plug-in socket.
4. Connect the power cable again to the left side of the control box.



Spare fuse:

Order-No.: **1ESI6300**

(Range of use **110-230VAC 50-60Hz**)

Connect the Vario Drive control box to the power network and launch it for operational use.



For fuse replacing from the fixly installed control box in the HM-2000 EVO, please follow the respective instruction manual of the HM-2000 EVO workstation.

14 Technical data

The following specifications are in context with the Vario Drive System. Specifications for other devices (VGX-21) and equipment can be reviewed in the respective instruction manuals.

VARIO DRIVE

<i>Dimensions Vario Drive assembly:</i>	400x175x285mm (width x depth x height)
<i>Dimensions Vario Drive control box:</i>	80x100x285mm (width x depth x height)
<i>Weight:</i>	15kg
<i>Operating range with flexible shaft:</i>	600mm in Radius
<i>Rotational-speed range:</i>	0-200min⁻¹
<i>Power supply:</i>	230VAC, 50Hz
<i>Type power cable:</i>	Schuko (EU) / Swiss type (CH)
<i>Output - control box:</i>	1x230VAC 50Hz / 1x24VDC
<i>Nominal power:</i>	550W
<i>Fuse:</i>	2x6,3A (parallel)
<i>Type of switch for the hand grip:</i>	4-pole, switch key button OFF-(ON)
<i>Type rotary potentiometer:</i>	10kΩ Cermet, linear±20%, IP67



Notes

Lined area for notes, consisting of multiple horizontal lines.



Manufacturer and worldwide distributor:

MINELLI CORPORATION
Mattenstrasse 3
8330 Pfäffikon ZH
Switzerland

www.miratool.ch

Your local distributor: