

MIRA[®]

BB-86 EXTENSION

**Instruction manual
English (EN)**

BB-Extension kit

**For refacing of deep
counterbores with
MIRA-BB**

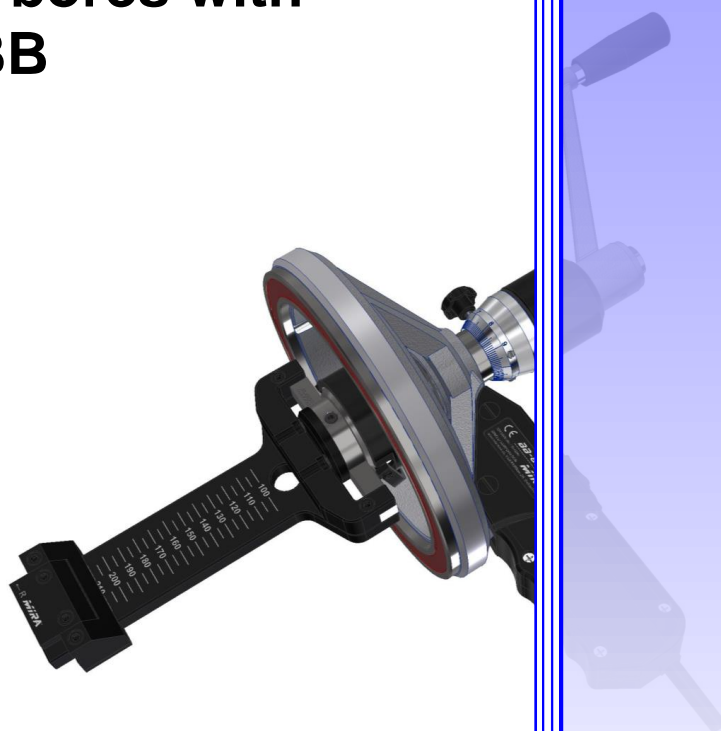
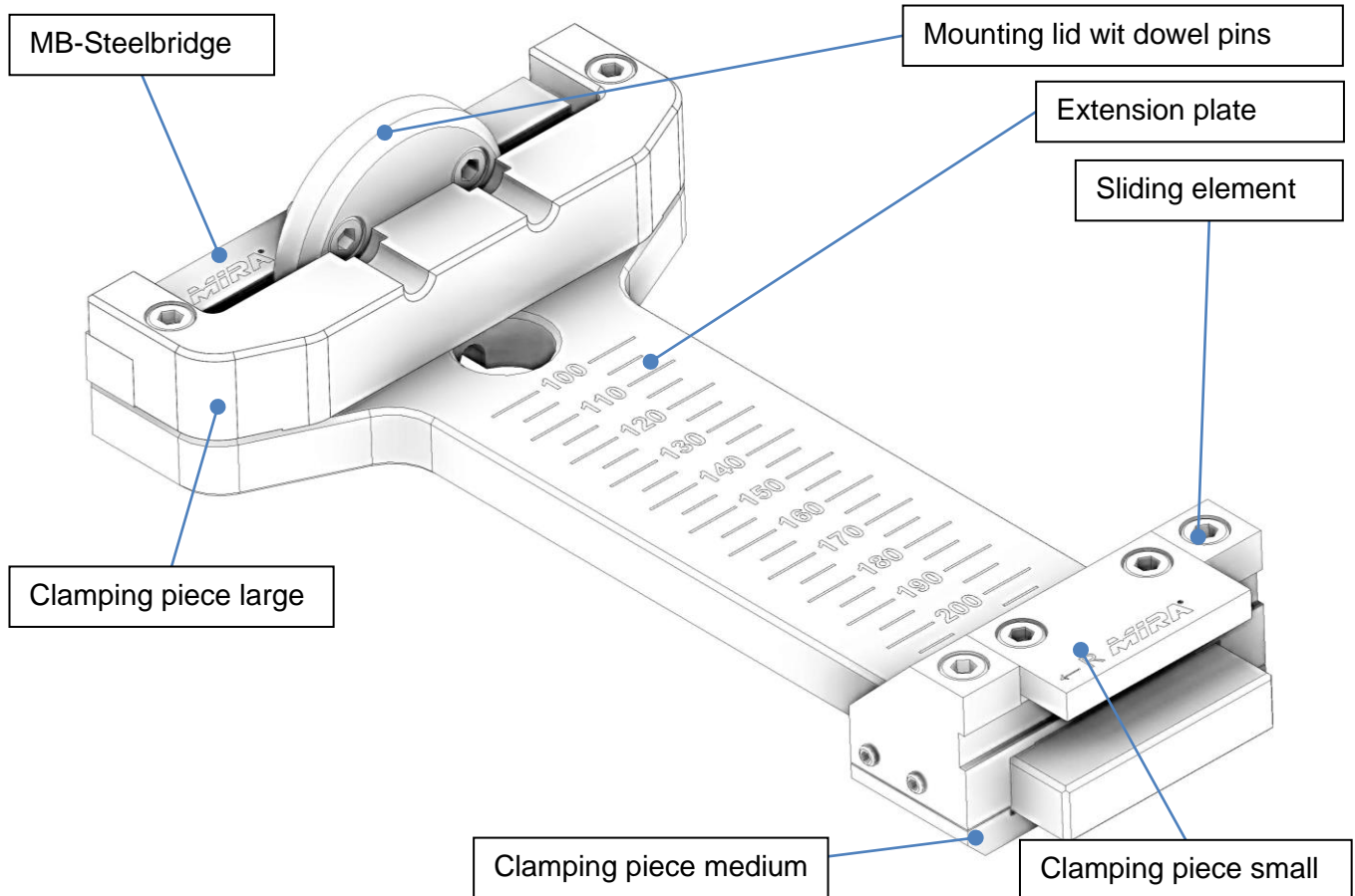

Table of contents

1	Overview	2
2	Package contents	2
3	Dimensions and weight.....	3
4	Preconditions for operation.....	3
5	Operating	4
6	Maintenance and spare parts	5
6.1	Cleaning and care.....	5
6.2	Spare parts list to spare parts drawing BB-86 Extension.....	5
6.3	Spare parts drawing BB-86 Extension	6

1 Overview



2 Package contents

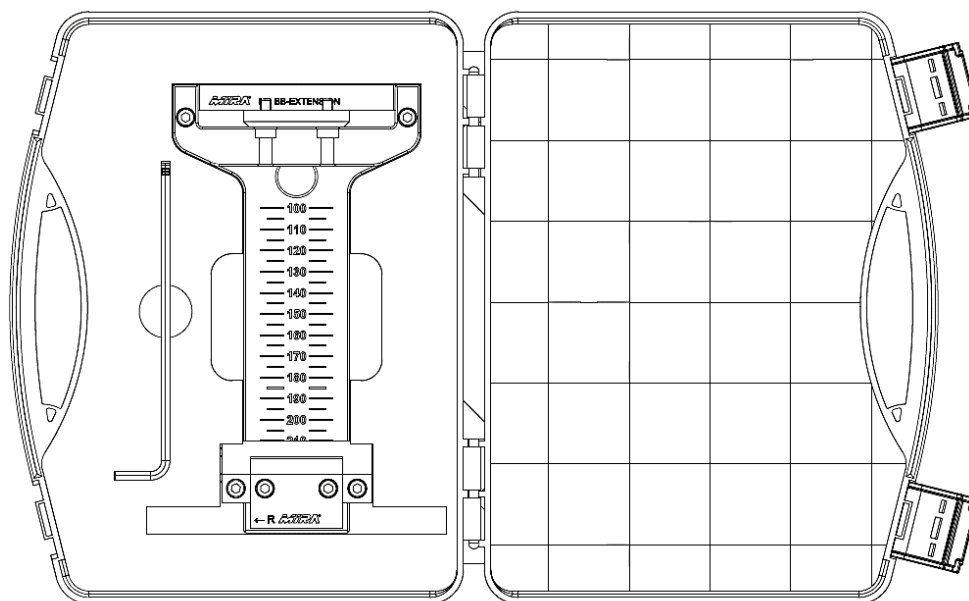

- 1x Tooling case BB Extension
- 1x BB-86 Extension (pre-assembled)
- 1x Allen key with ball head
- 1x Instruction manual EN

3 Dimensions and weight

Dimensions in mm:

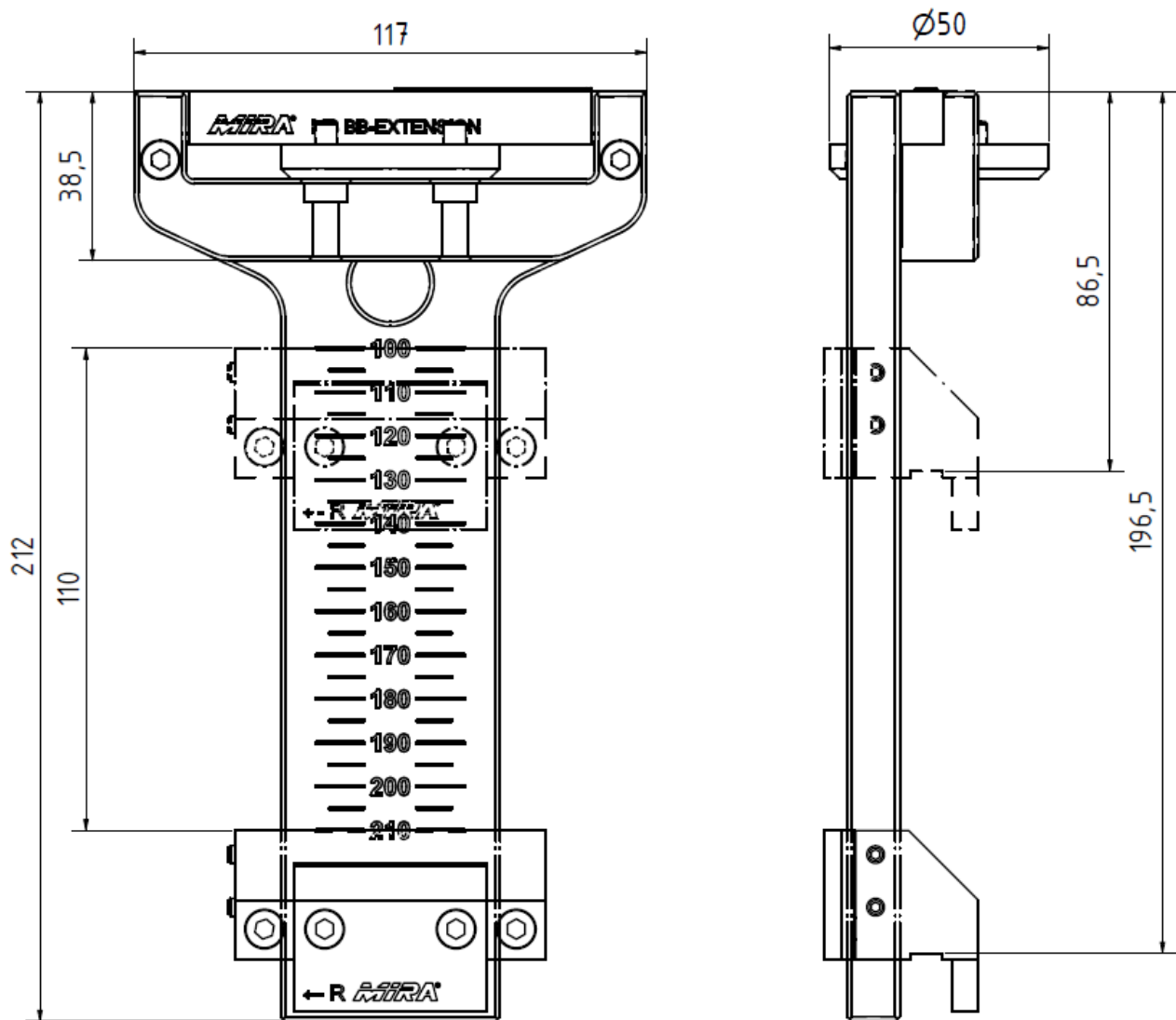

Weight: 2 kg (without BB-Unit)

4 Preconditions for operation



Preconditions for flawless machining and precise results are:

- A properly functioning BB-86 and a fully cleaned bottom side
- Clean turning tools, fitted with flawless carbide cutting edges (wear-free)
- An absolutely clean and flat (evenness) clamping surface, free of any dirt residues
- Perfectly functioning BB-spindle with plan and axial feed unit
- Smooth crank handle rotation throughout the entire machining process
- Depending on the material, use cutting oil or methylated spirits for better cutting results
- Check the individual parts of the BB-86 Extension for tight fit
- Moveability of the sliding element in loose condition (without play)

5 Operating

1. Measure the depth down to the counterbore.

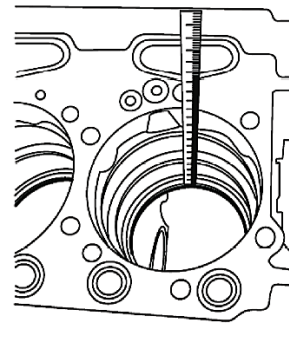

2. Set the depth according to the scale on the extension.

⇒ Clamp the sliding element with the two outer allen screws

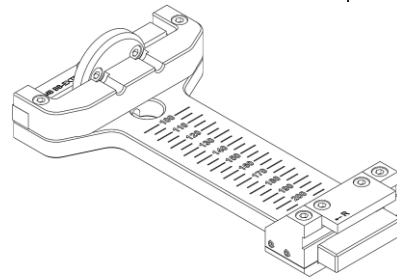

3. Install the extension on the BB-86 unit.

⇒ Pay attention to the centering roll side when mounting the unit!
⇒ See “← R”

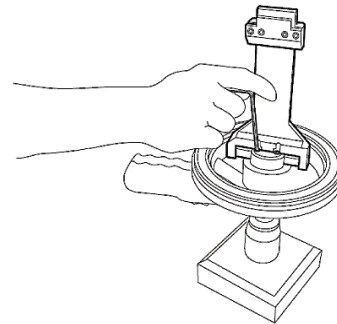

4. Install the cutting tool for actual diameter, centered in the tool holder (=same distance on both sides).

⇒ Clamp the small clamping piece with the two inner allen screws
⇒ Make sure that the turning toll is straight on all sides

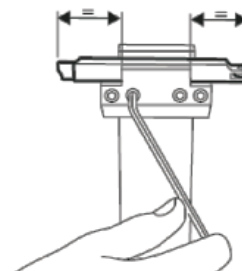

5. Center the device and cut the counterbore seat the same way as it is done without the extension.

=> See also the BB-86 instruction manual

=> Attention! Take a maximum of 0,05mm in each cut!

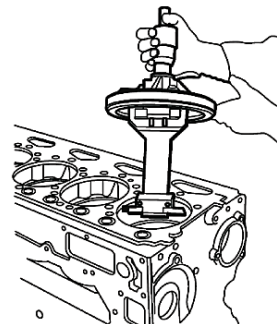

6 Maintenance and spare parts

6.1 Cleaning and care



Before each use:

- Extension must be free of grease
- Clean the scale before use
- Don't clean the extension with compressed air
- Control fixation of screws and functionality of the elements (Moveability)
- Clamp the MB-Steel bridge correctly

After each use:

- Clean cooling lubricant from the extension
- Remove chips from the extension with a brush
- Dry the extension with a soft, lint-free cloth
- Rust protection as required
- Store in tooling case

6.2 Spare parts list to spare parts drawing BB-86 Extension

When ordering spare parts, always state the serial number and the fabrication number of the unit.

Spare parts valid with Serial-No.: 0518

from manufacturing-No.: 0100 < ...

Description	Pos.	Quantity	Part-No.:
Mounting lid with dowel pins	1	1	101550.2.6245
MB-Steelbridge	2	1	101550.2.6250
Extension plate	3	1	101550.1.6242
Clamping piece large	4	1	101550.1.6243
Sliding element	5	1	101550.1.6246
Clamping piece medium	6	1	101550.1.6247
Clamping piece small	7	1	101550.1.6248
Setscrew M4	8	2	1KDS00400
Allen screw	9	2	1N0272M05x030
Allen screw	10	2	1N0002M05x030
Allen screw	11	2	1N0272M05x012
Allen screw	12	3	1N0272M05x008

6.3 Spare parts drawing BB-86 Extension

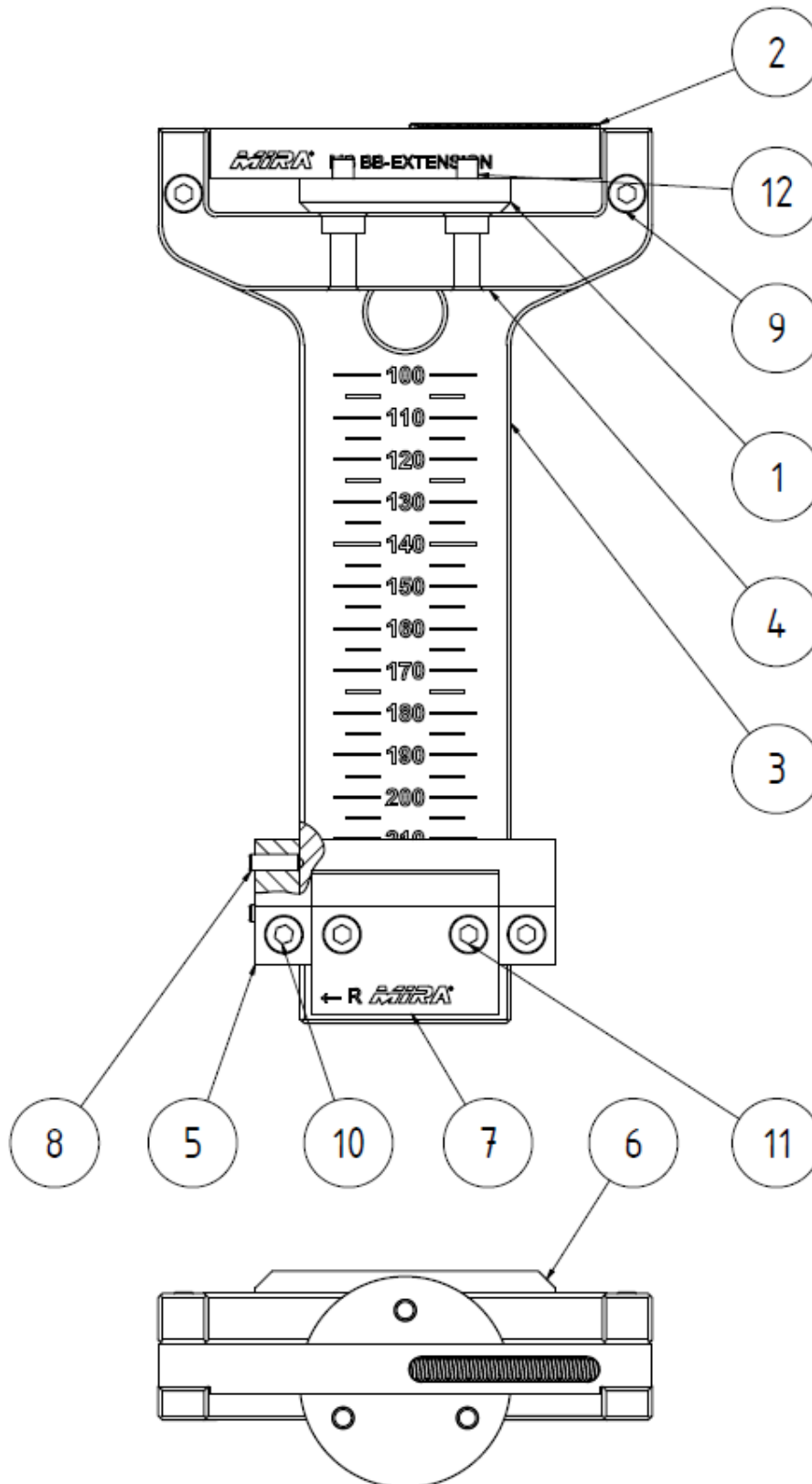



Manufacturer and worldwide distributor:

MINELLI CORPORATION
Mattenstrasse 3
8330 Pfäffikon ZH
Switzerland

www.miratool.ch

Your local distributor: